

Cylinder regulator FE 121

spectro**cem**

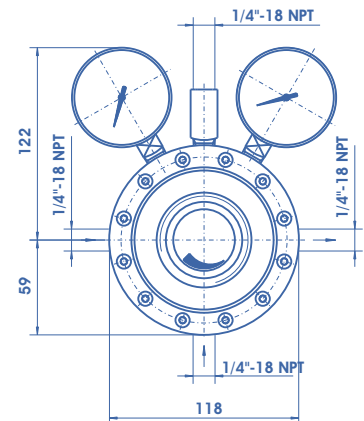

Cylinder regulator
FE 121 SP



Dimensions
FE 121

Product features

- Single-stage cylinder pressure regulator
- Simple and safe gas withdrawal from gas cylinders, for non-corrosive gases and gas mixtures up to quality 6.0 with a maximum of 1% corrosive components and up to 25 bar vapour pressure
- For corrosive gases and gas mixtures with >1% corrosive components we recommend the use of a purging device (FE 121 SP)
- new laboratory-style design
- ergonomically designed
- Filter at the regulator inlet
- high control accuracy due to large diaphragm
- integrated relief valve
- available with purge device FE 121 SP
- Simple outlet pressure limitation by handwheel
- powder-coated bonnet

Technical data

Inlet pressure P_1	max. 25 bar
Max. Outlet pressure P_2	0,05 - 1,5 bar (higher values upon request)
Flow rate Q	max. 9m ³ /h ¹⁾
Materials	
Body:	SS 1.4404 (SS 316 L)
Diaphragm:	Hastelloy C276
Valve seat:	PCTFE (Kel-F)
Inlet gasket:	PCTFE
Cylinder connector	acc. to international standards and gas type
Outlet connector	1/4"-18 NPT-F
Leak rate	10 ⁻⁸ mbarl/s He
Weight	2,1kg
¹⁾ see flow curves	

Flow curves cylinder regulator FE 121 - Inlet pressure $P_1 = 4$ bar

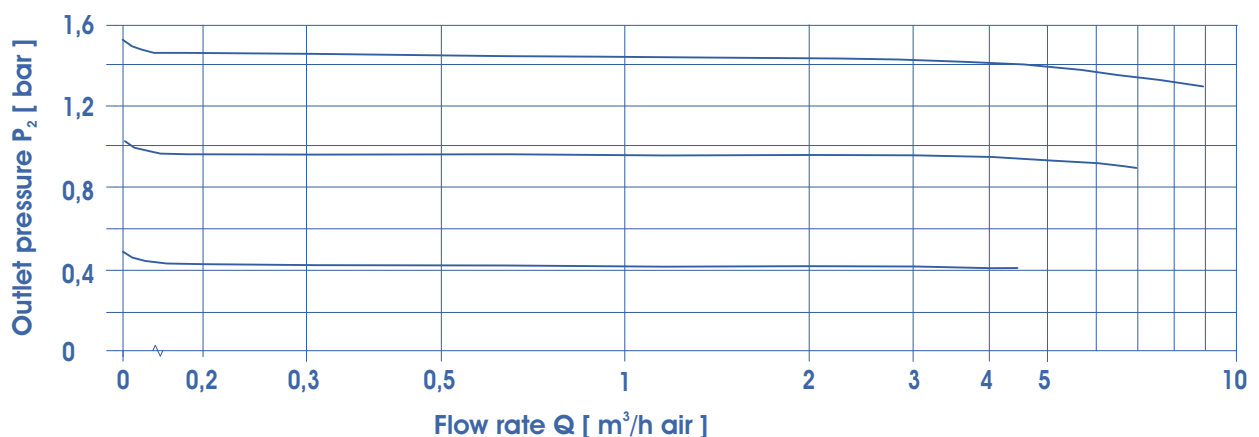

Cylinder regulator FE 121

spectro**cem**

Cylinder regulator FE 121 SP

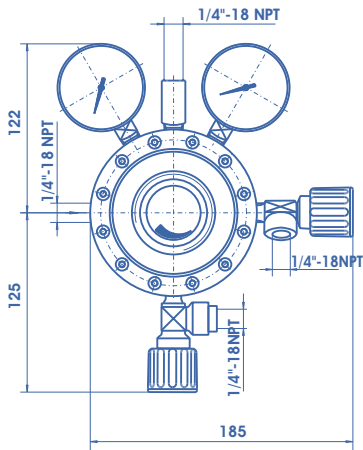

Side view FE 121

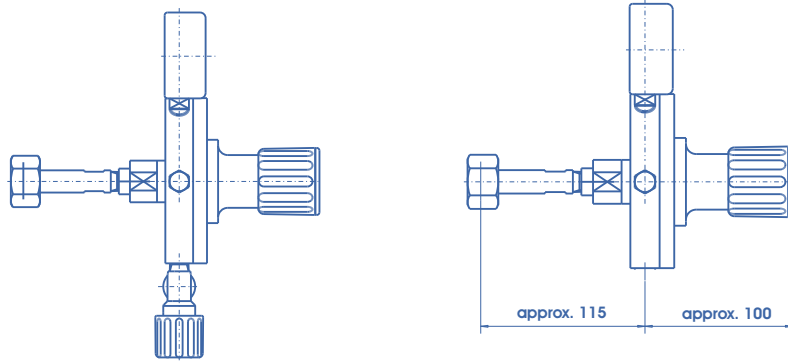

Additional configurations upon request!

Ordering information: Cylinder regulators FE 121

FE 121 - 25 - 1,5 - DIN 6 - NH₃

Type

121 - single-stage without purge device
121 SP - single-stage with purge device

Inlet pressure P_1

25 - max. 25 bar
Others upon request

Outlet pressure P_2

1,5 - up to 1,5 bar
Others upon request

Gas type

Please specify gas type!
(Valve seat material)

Cylinder connection

Detailed description of the cylinder connection including the relevant standard and the connection number (e.g. BS no. 3)

Specifications

- SPECTROCEM - components guarantee maximum quality by using high grade materials and a quality assurance program acc. to ISO 9001.
- All components which come into contact with the medium are cleaned in an ultrasonic cleaning system (CFC-free) with the special cleaning process SPECTRO-CLEAN® and are then baked out.
- SPECTROCEM - components undergo a 100% function- and Helium-leak-test.

Pressure indication

- All pressure regulators are equipped with pressure gauges for inlet- and outlet pressure indication.

Important note regarding component selection

- In order to assure safe operation it is essential to take the configuration of the whole system into account when selecting a pressure regulator.
- The function of the regulator, the compatibility of the materials, correlating temperature ranges, correct installation, operation and maintenance in accordance with the relevant regulations are the responsibility of the system designer and the user.